

SCM Series

Common Mode Filter

Size 3225



FEATURES

- High common mode impedance for outstanding noise suppression performance.
- Small influence on high speed signals through good coupling.
- Operating temperature $-40\sim+125^{\circ}\text{C}$ (Including self - temperature rise)
- Excellent solderability

APPLICATIONS

- USB2.0 lines for PC, TV, Peripheral equipments
- Standard signal lines
- Audio lines
- Power lines

Dimensions: [mm]

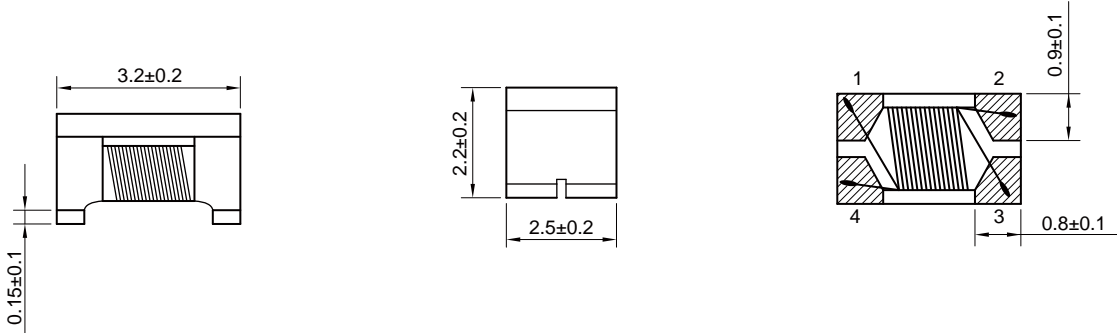

Schematic:

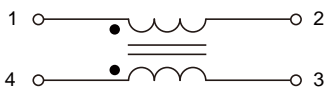

Land Pattern: [mm]

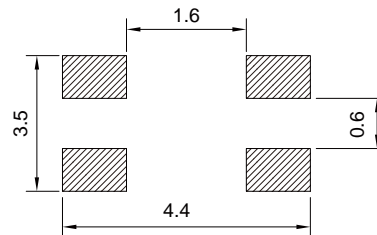

Electrical Properties:

| | | | | | | | |
|--|--|--|--|--|--|--|--|
| | | | | | | | |
| | | | | | | | |
| | | | | | | | |
| | | | | | | | |

Typical Electrical Characteristics:

