

SCM Series

Common Mode Filter

Size 1210



FEATURES

- High self-resonance frequency enables high cut-off frequency, wide band noise suppress in high frequency.
- Small size and low profile.
- Operating temperature $-40\sim+125^{\circ}\text{C}$ (Including self - temperature rise)
- Small size and low profile.
- c t i

APPLICATIONS

- USB 3.0 lines
- AV interfaces, such as HDMI 1.3/1/4
- High-speed signal lines

Dimensions: [mm]

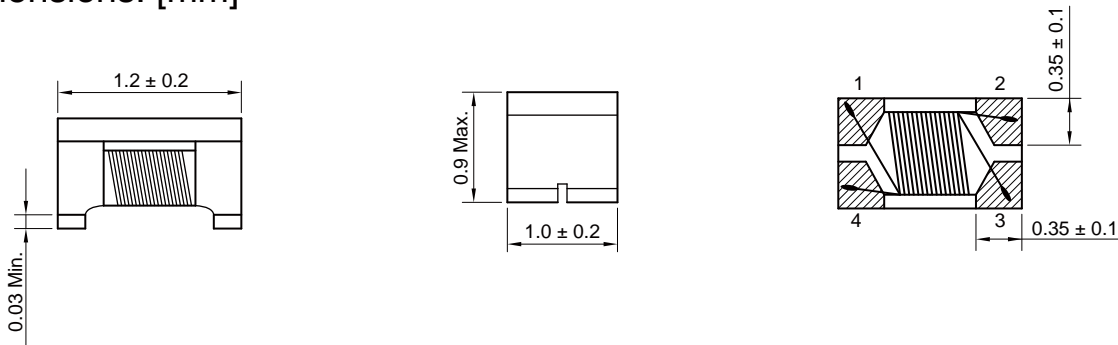

Schematic:

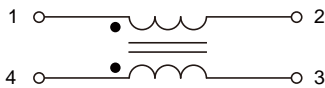

Land Pattern: [mm]

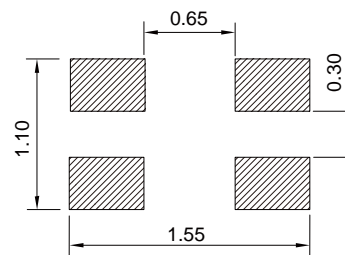

Electrical Properties:

Part No	Impedance @ 100 MHz	Tolerance	DC Resistance Max.	Rated Current Max.	Rated Volt	Withstand Volt	IR Min.
SCM1210HS-350-02	35	±25%	0.30	200	50	125	10
SCM1210HS-500-02	50	±25%	0.30	250	50	125	10
SCM1210HS-600-02	60	±25%	0.30	250	50	125	10
SCM1210HS-900-02	90	±25%	0.40	200	50	125	10
SCM1210HS-900-04	90	±25%	0.40	400	50	125	10

Typical Electrical Characteristics:

Soldering Reflow:

Packaging Information:

Tape Dimension:

Series	A0 (mm)	B0 (mm)	D (mm)	P0 (mm)						
SCM1210HS	1.12±0.1	1.40±0.1	1.5±0.1	4.0±0.1	4.0±0.1	8.0±0.3	1.05±0.1	1.75±0.1	0.22±0.05	

Peel force of top cover tape:

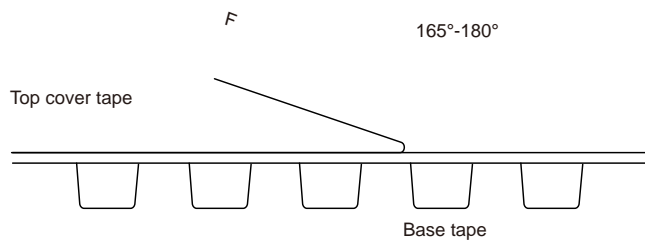

The peel force of top cover tape shall be between 0.15 to 0.78 N

Reel Dimension: [mm]

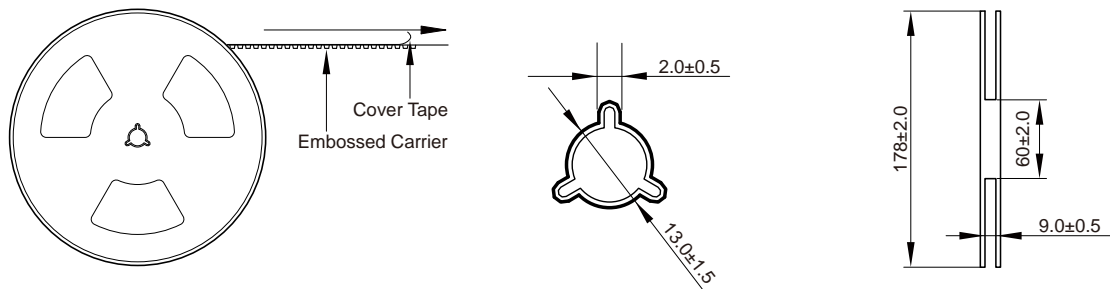

Packaging Quantity:

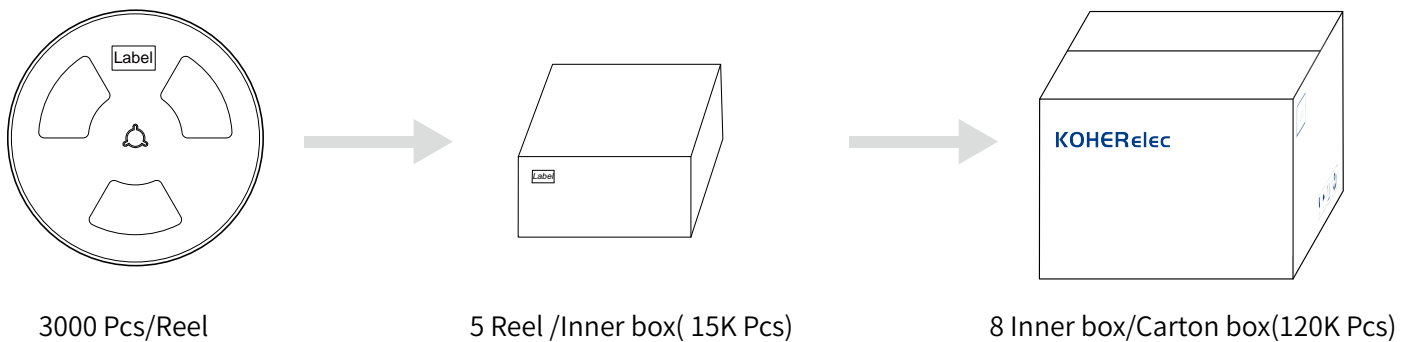

Cautions and Warnings:

Storage Conditions:

- The storage period is within 12 months after the completion of production. Be sure to follow the storage conditions (temperature: -5 to 35°C, humidity: 75% RH Max). If the storage period elapses, the soldering of the terminal electrodes may deteriorate. The warranty period is one year.
- Product should not be exposed to environment with high temperature, high humidity, dust, corrosive gas and etc.
- Products should be handled with care to avoid damage or contamination from perspiration and skin oils.
- Please always handle products carefully to prevent any damage caused by dropping down or inappropriate removing.

Operation Instructions:

- Self heating (temperature increase) occurs when the power is turned ON, so the tolerance should be sufficient for the set thermal design.
- Before soldering, be sure to preheat components. The preheating temperature should be set so that the temperature difference between the solder temperature and chip temperature does not exceed 150°C.
- Soldering corrections after mounting should be within the range of the conditions determined in the specifications. If overheated, a short circuit, performance deterioration, or lifespan shortening may occur.
- Generally, Koher might not be familiar with either customer's specific application or actual requests as customer does. As a result customer shall be responsible for checking and confirming whether Koher product with the performance described in the product specification is suitable for using in customer's particular application or not.