

## ACMA Series

### FEATURES

- 

- 

- 

- 

- 

### APPLICATION

-

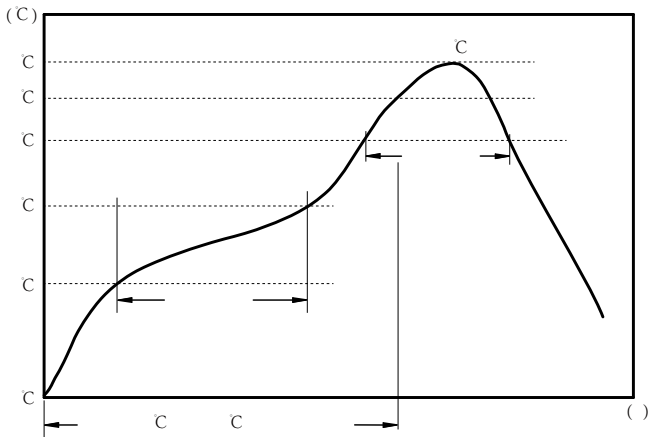

c  
c  
c

:

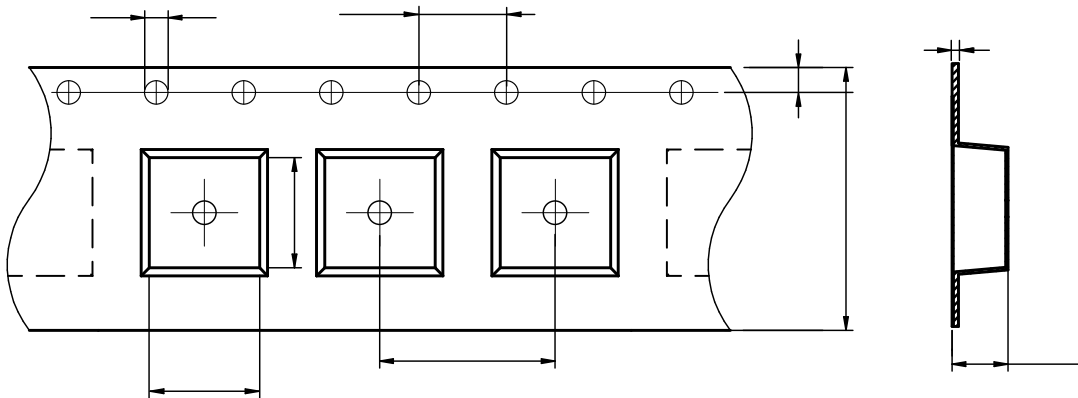

ACMA4532ETH	3.60±0.1	4.90±0.1	1.5±0.1	4.0±0.1	8.0±0.1	8.0±0.3	3.0±0.1	1.75±0.1	0.26±0.05
-------------	----------	----------	---------	---------	---------	---------	---------	----------	-----------

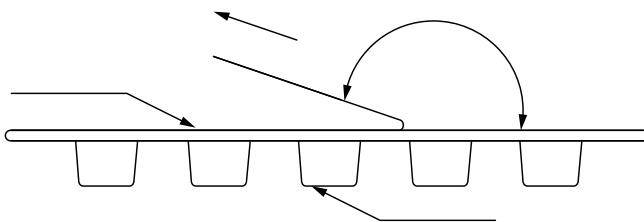

The peel force of top cover tape shall be between 0.14 to 0.78 N

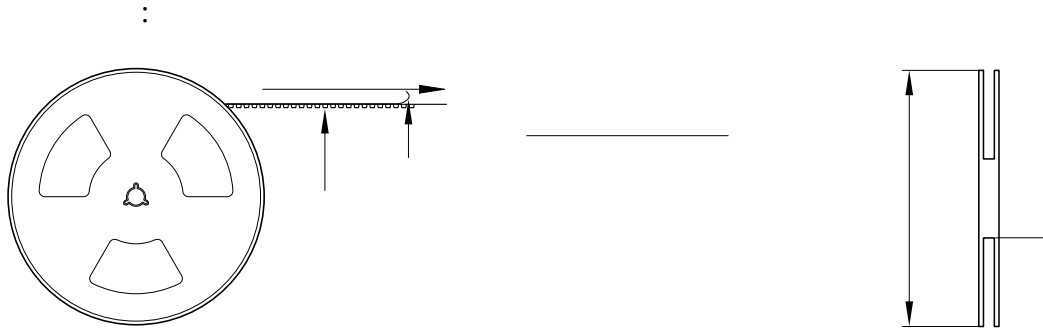

:

- 
- 
- 
- 
- 
- 
- 
- 
-